

NOTE: A GRADE BREAK SHOULD NOT BE PLACED BETWEEN THE TURNING SPACE AND BOTTOM OF RAMP, UNLESS A LANDING IS REQUIRED FOR SIGNAL PUSH BUTTONS, OR IN THE CASE OF LONG RAMP. GRADE SHOULD GENERALLY BE CONSTANT BETWEEN GRADE BREAK AT BOTTOM OF RAMP AND TURNING SPACE.

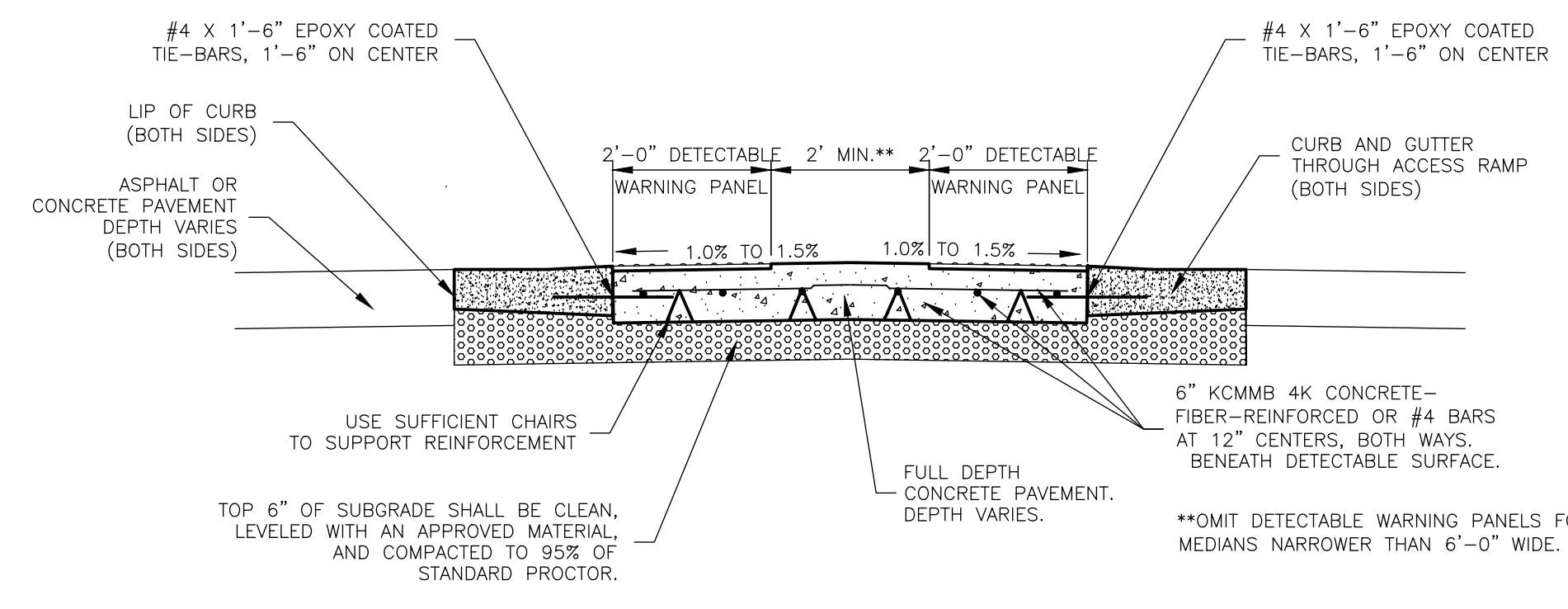
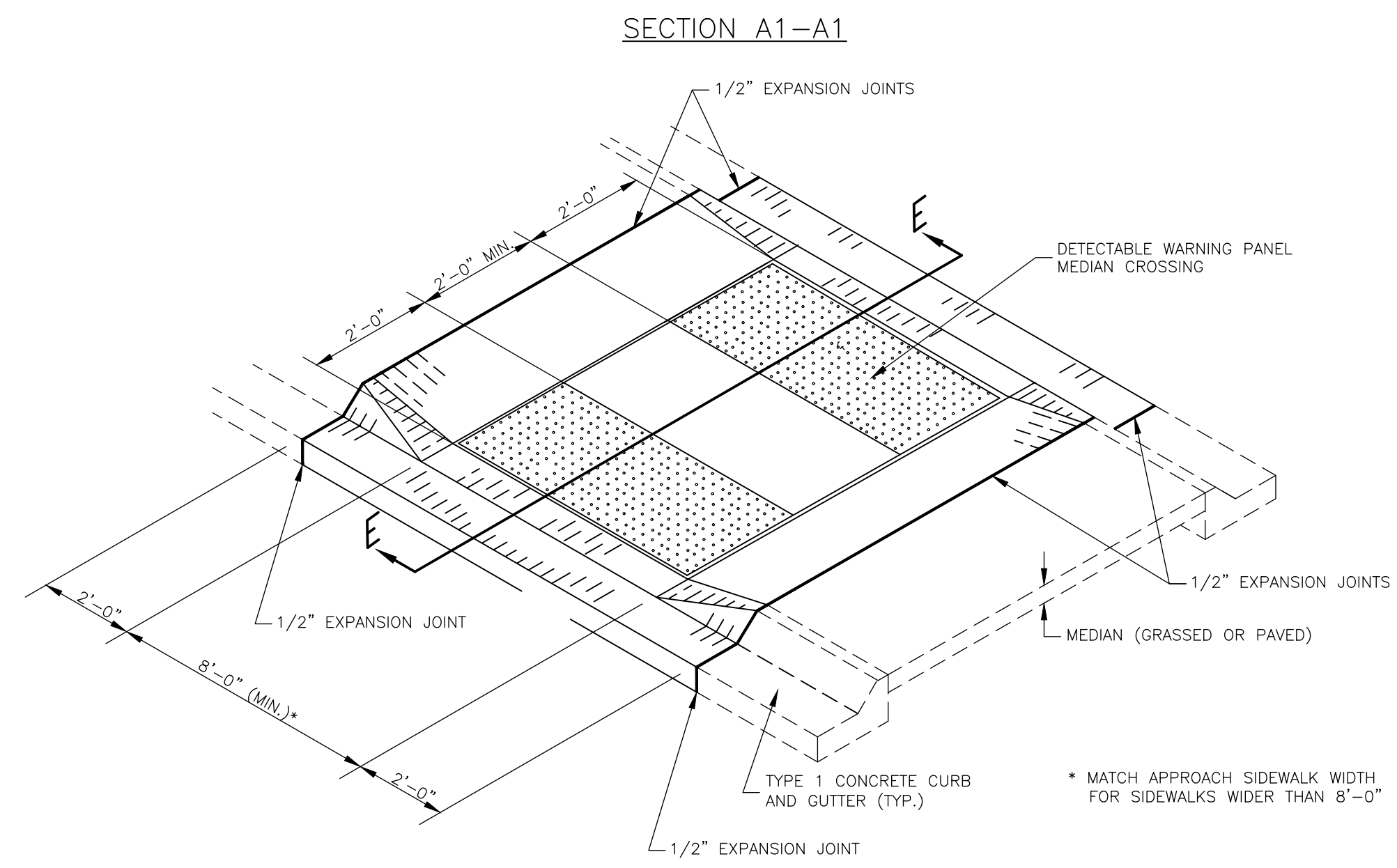
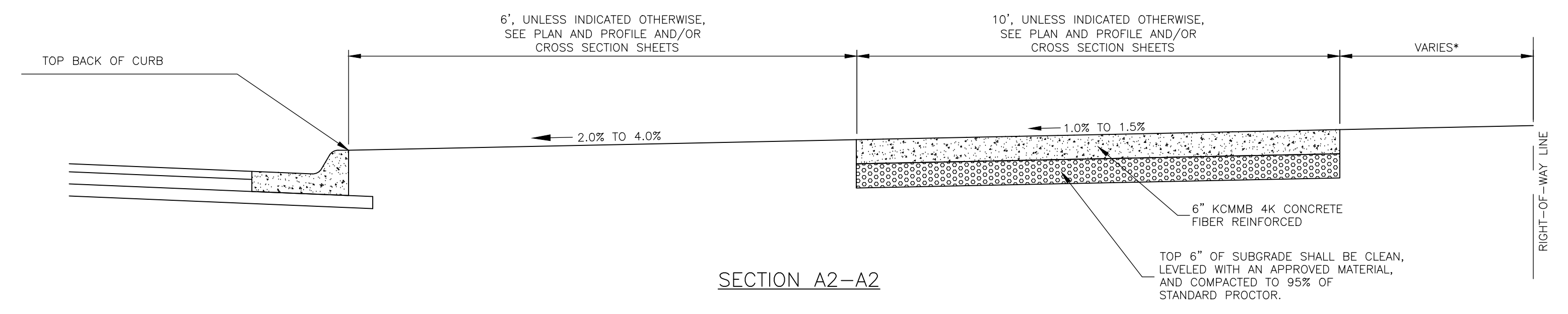
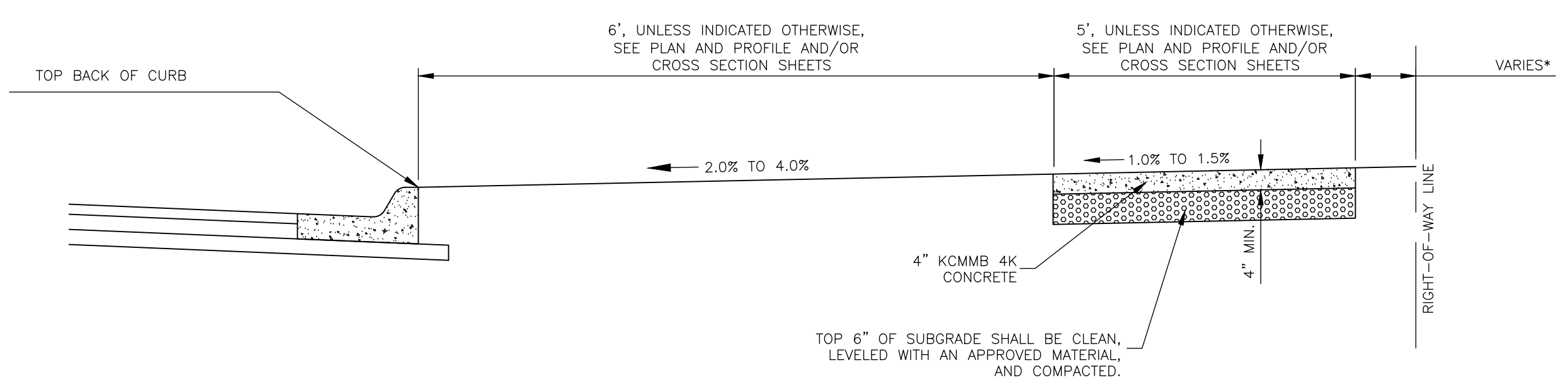
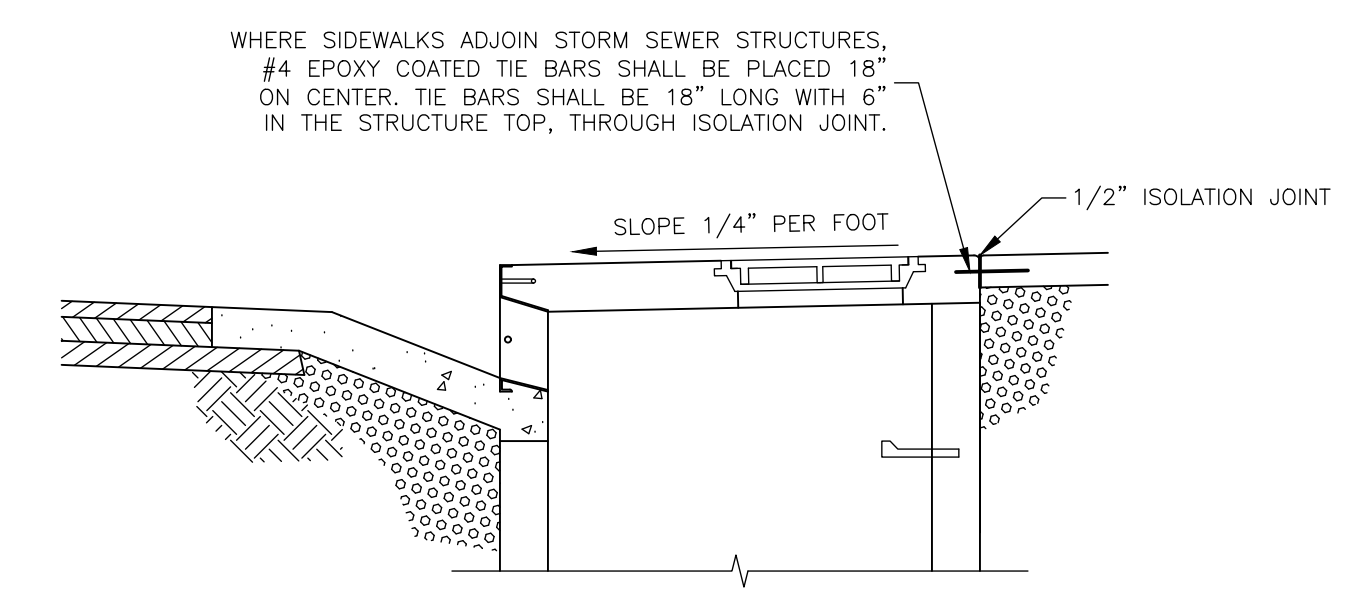
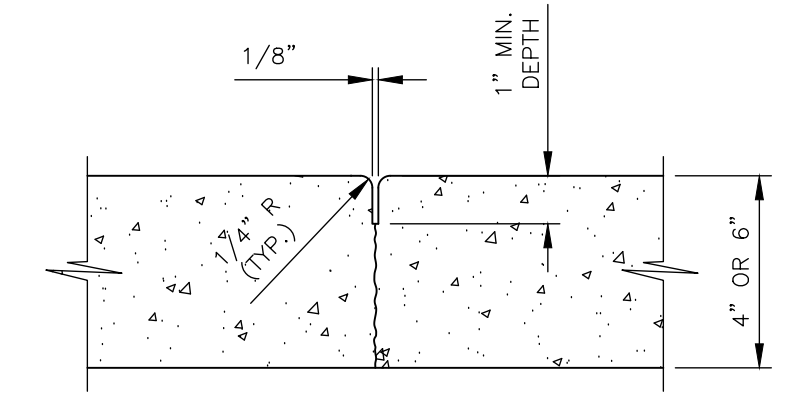

- SIDEWALK GENERAL NOTES**
- CONSTRUCTION JOINTS SHALL BE PLACED IN 5'-0" WIDE SIDEWALKS AT A MINIMUM OF 5'-0" INTERVALS. WHEN OTHER WIDTHS OF SIDEWALK ARE USED, CONSTRUCTION JOINTS SHALL BE PLACED AS DIRECTED BY THE CITY ENGINEER OR AN AUTHORIZED REPRESENTATIVE.
 - ISOLATION JOINTS SHALL BE PLACED AT ALL LOCATIONS WHERE SIDEWALK ABUTS EXISTING STRUCTURES AND AS DIRECTED BY THE CITY ENGINEER OR AN AUTHORIZED REPRESENTATIVE.
 - ACCESS RAMP SHALL BE CONSTRUCTED AT ALL LOCATIONS WHERE SIDEWALKS INTERSECT NEW STREET CONSTRUCTION AND AS OTHERWISE SHOWN ON THE PLANS.
 - ALL SHARED USE PATH JOINTS SHALL BE SAW CUT.
 - ALL SIDEWALKS AND RAMP MUST BE CONSTRUCTED TO CURRENT PROWAG STANDARDS.
 - THERE SHALL BE NO GRADE BREAKS ON THE RAMP. GRADE SHOULD BE CONSTANT BETWEEN GRADE BREAK AT BOTTOM OF RAMP AND TURNING SPACE.
 - SIDEWALK CURB FOR ADA COMPLIANCE IS SUBSIDIARY TO THE RAMP.
 - GRADING REQUIRED TO FACILITATE DRAINAGE BETWEEN THE SIDEWALK AND CURB IS SUBSIDIARY TO THE RAMP.

2022 EDITION SHEET ____ OF ____

DATE	BY	REVISION
07-07-22	LJM	ALLOWS FOR THE USE OF CONCRETE-FIBER-REINFORCEMENT IN RAMP
03-01-21	LJM	REPLACES ALL PREVIOUS VERSIONS OF CONCRETE SIDEWALK AND SHARED USE PATH LAYOUTS DETAILS

City of Lawrence
MUNICIPAL SERVICES & OPERATIONS

STANDARD DETAILS FOR
CONCRETE SIDEWALK AND SHARED USE PATH LAYOUTS

DAVID P. CRONIN CITY ENGINEER CRAIG S. OWENS CITY MANAGER

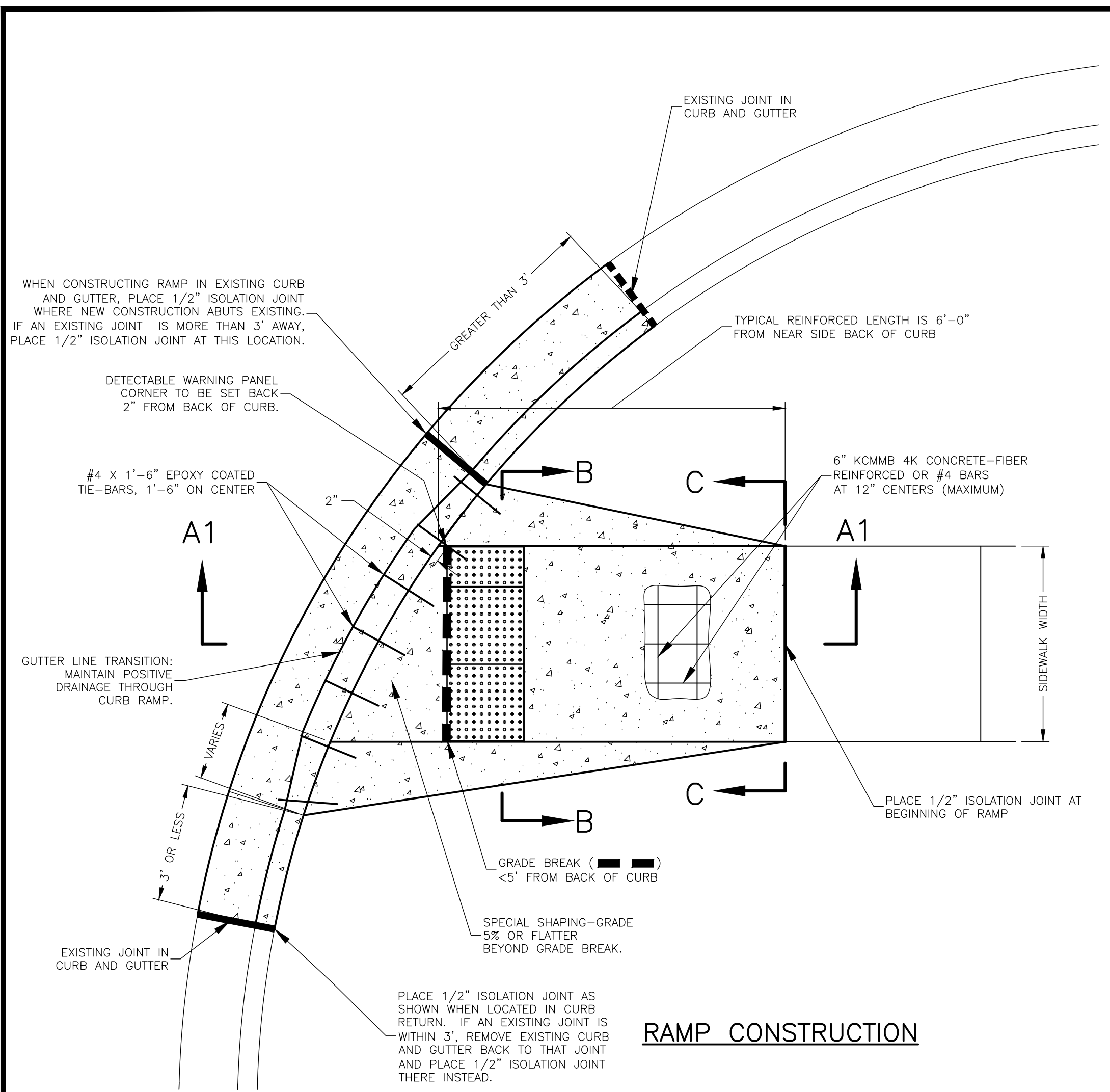

RAMP CONSTRUCTION

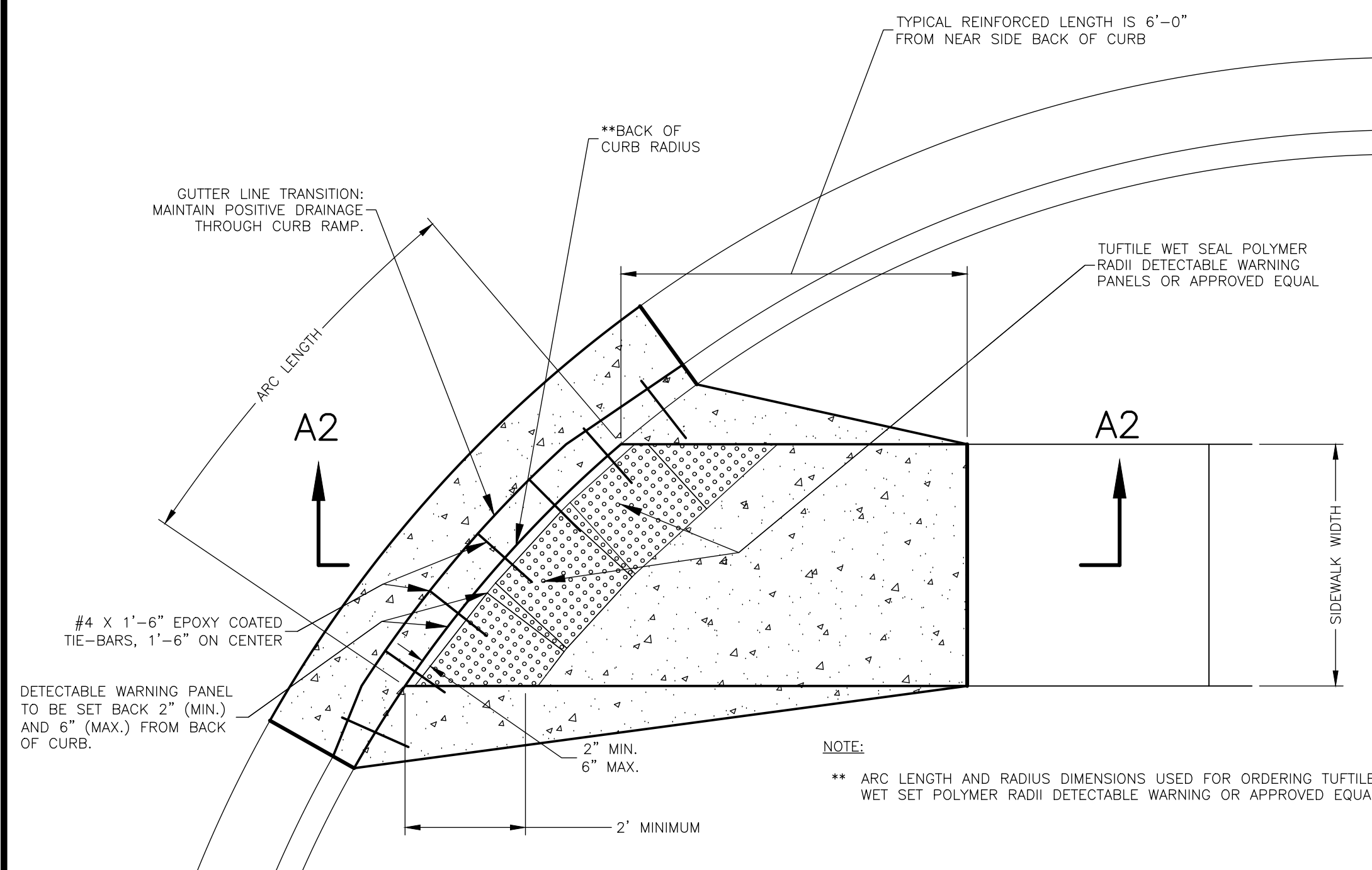

RAMP WITH RADIAL DETECTABLE WARNING

- NOTES**
- FLARED SIDES SHALL BE 10% OR FLATTER SLOPE, IF ADJACENT TO SIDEWALK, AND 25% OR FLATTER SLOPE, IF ADJACENT TO LANDSCAPED AREAS.
 - IF THE SPECIAL SHAPING DISTANCE EXCEEDS 5' FROM THE BACK OF CURB, THEN REFER TO THE "BLENDED TRANSITION DETECTABLE WARNING SURFACE DETAIL". IF USING RADIAL DETECTABLE WARNINGS, BLENDED TRANSITION SHOULD HAVE A 4% OR FLATTER SLOPE.
 - DETECTABLE WARNING DOMES SHALL BE ALIGNED PERPENDICULAR TO THE GRADE BREAK BETWEEN THE RAMP RUN AND STREET, UNLESS A BLENDED TRANSITION AND USING RADIAL DOMES.
 - DETECTABLE WARNINGS SHALL CONTINUOUSLY EXTEND FOR A MINIMUM OF 24" IN THE PATH OF TRAVEL.
 - DIMENSIONS SHOWN IN THIS DRAWING ARE TARGET DESIGN VALUES. ALL SIDEWALKS AND RAMPS MUST BE CONSTRUCTED TO CURRENT PROWAG STANDARDS.
 - IF GRADES DO NOT ALLOW RAMP TO BE CONSTRUCTED BASED ON SLOPES SHOWN, OVERALL LENGTH MAY BE LIMITED TO 15'. EXACT LIMITS TO BE APPROVED BY THE ENGINEER.
 - COMPACTED SUBGRADE SHALL BE CLEAN, LEVELED WITH AN APPROPRIATE MATERIAL, AND COMPACTED.
 - THE TERMS "RAMP" AND "BLENDED TRANSITION" REFER TO THE GEOMETRIC REQUIREMENTS OF PROWAG, NOT PAY ITEMS. THE FIRST 6'-0" OF A RAMP OR BLENDED TRANSITION SHALL BE "REINFORCED CONCRETE SIDEWALK". BEYOND 6'-0", THE RAMP OR BLENDED TRANSITION, SHALL BE "CONCRETE SIDEWALK". DETECTABLE WARNINGS SHALL BE MEASURED SEPARATELY. TYPICAL BID ITEMS ARE:
 - CONCRETE SIDEWALK (4"), SY
 - CONCRETE RECREATIONAL PATH (6" FIBER REINFORCED), SY
 - INTEGRAL CONCRETE SIDEWALK AND RETAINING WALL, LF
 - REINFORCED CONCRETE SIDEWALK (ADJACENT TO CURB), SF
 - DETECTABLE WARNING PANELS, SF
 - DETECTABLE WARNING PANELS (RADIAL, XX FT. RADIUS), SF
 - CONCRETE MEDIAN REINFORCED SIDEWALK CROSSING, SF
 - SIDEWALK CURB FOR ADA COMPLIANCE IS SUBSIDIARY TO THE RAMP.
 - GRADING REQUIRED TO FACILITATE DRAINAGE BETWEEN THE SIDEWALK AND CURB IS SUBSIDIARY TO THE RAMP.

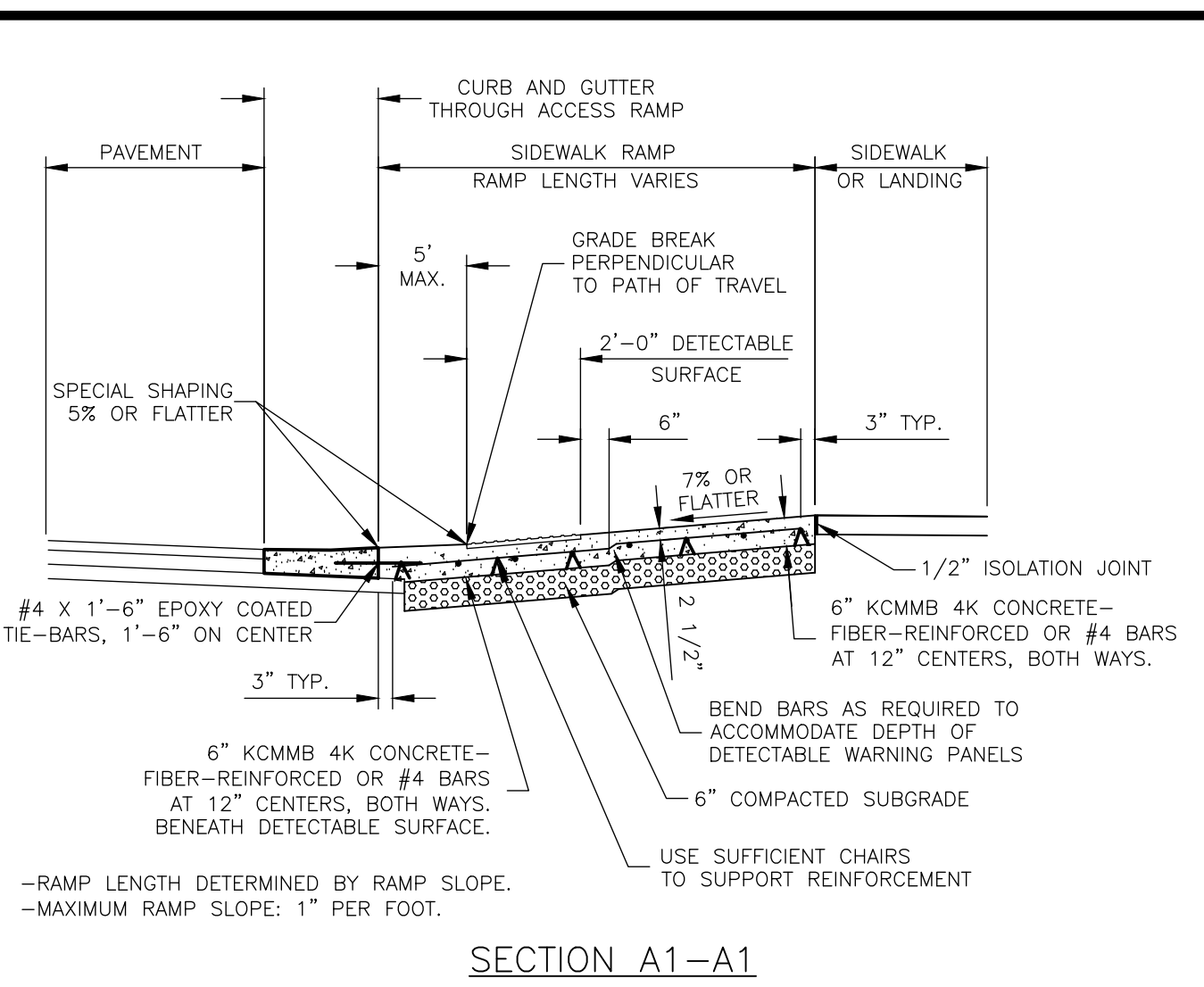

SECTION A1-A1

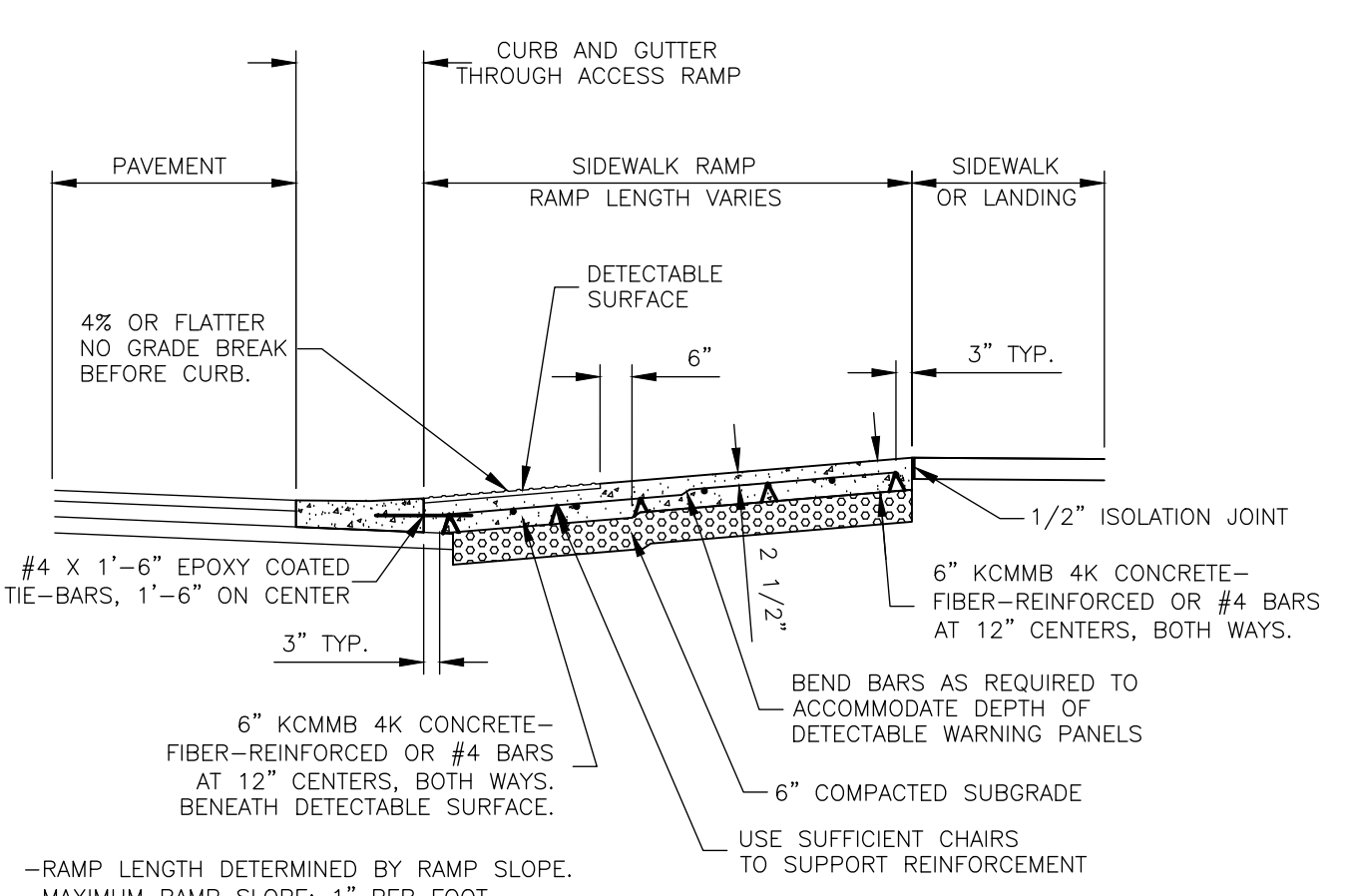

SECTION A2-A2

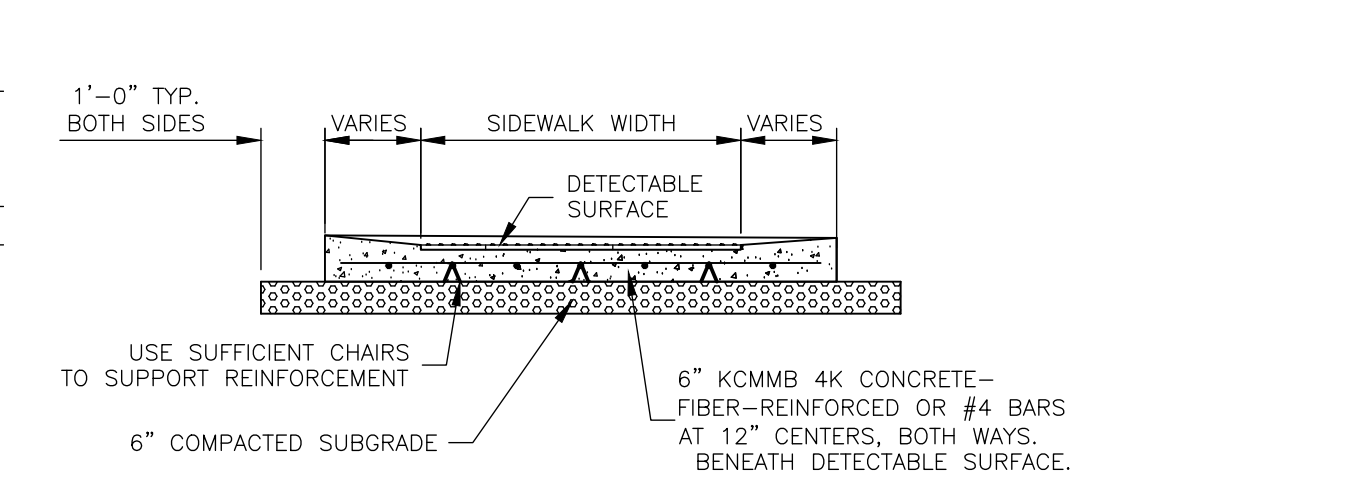

SECTION B-B

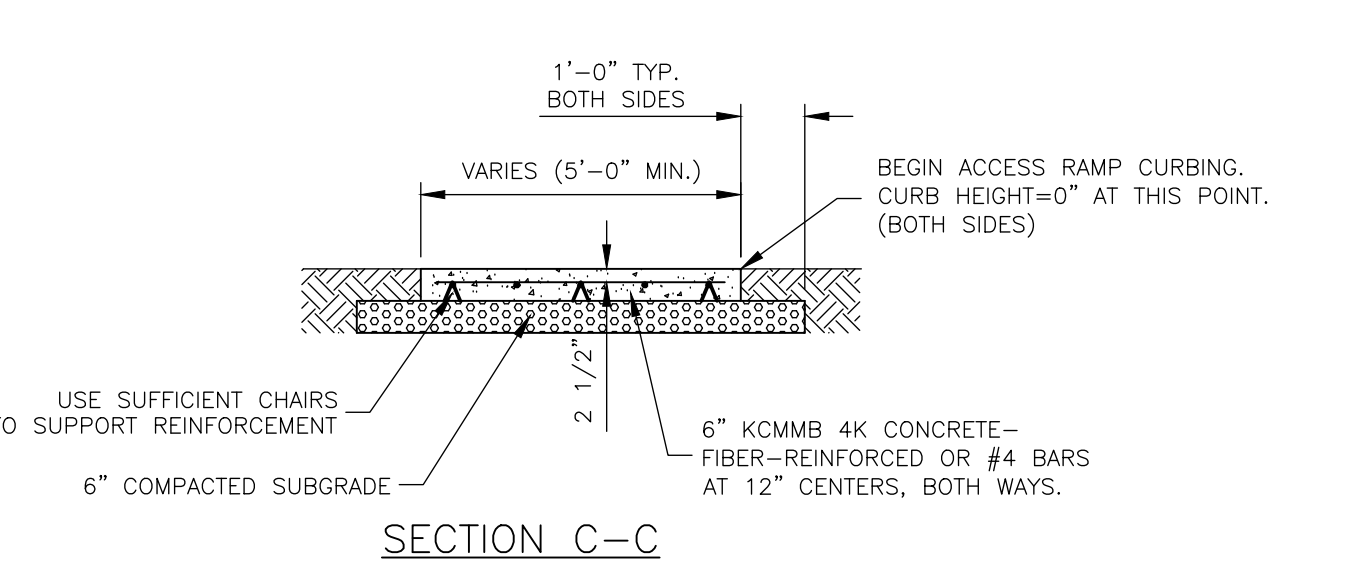

SECTION C-C

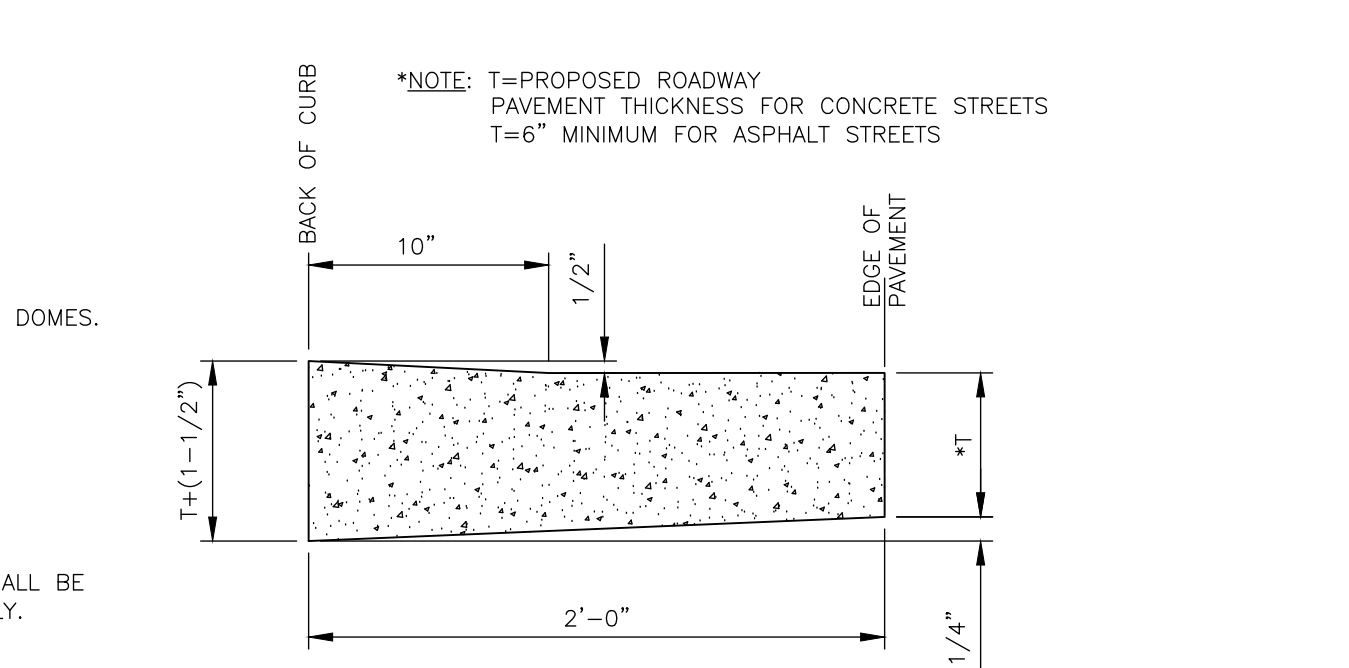

CURB AND GUTTER THROUGH ACCESS RAMP

PAID AS CURB TYPE ADJACENT TO CURB RAMP BY LINEAR FOOT

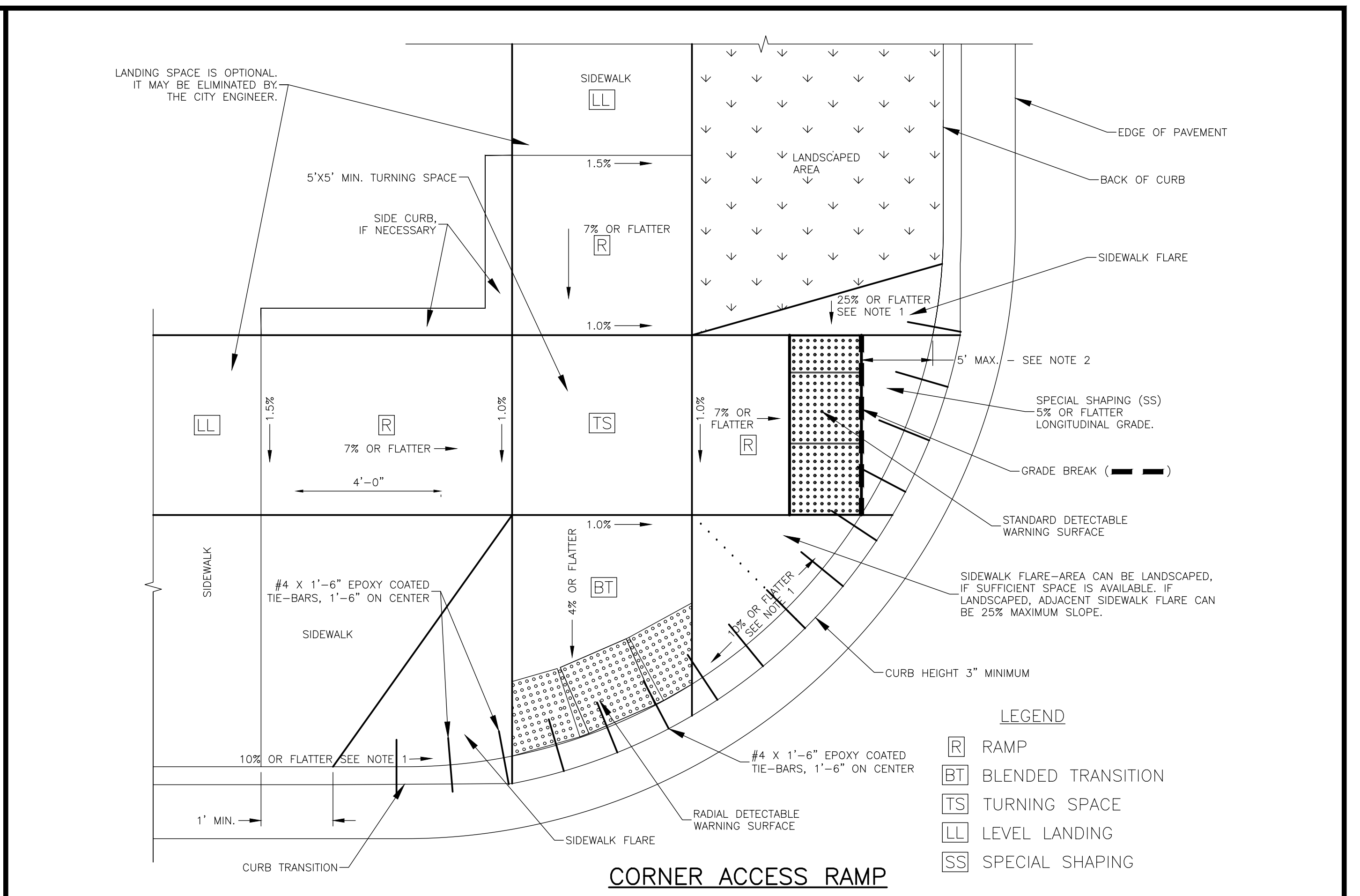

CORNER ACCESS RAMP

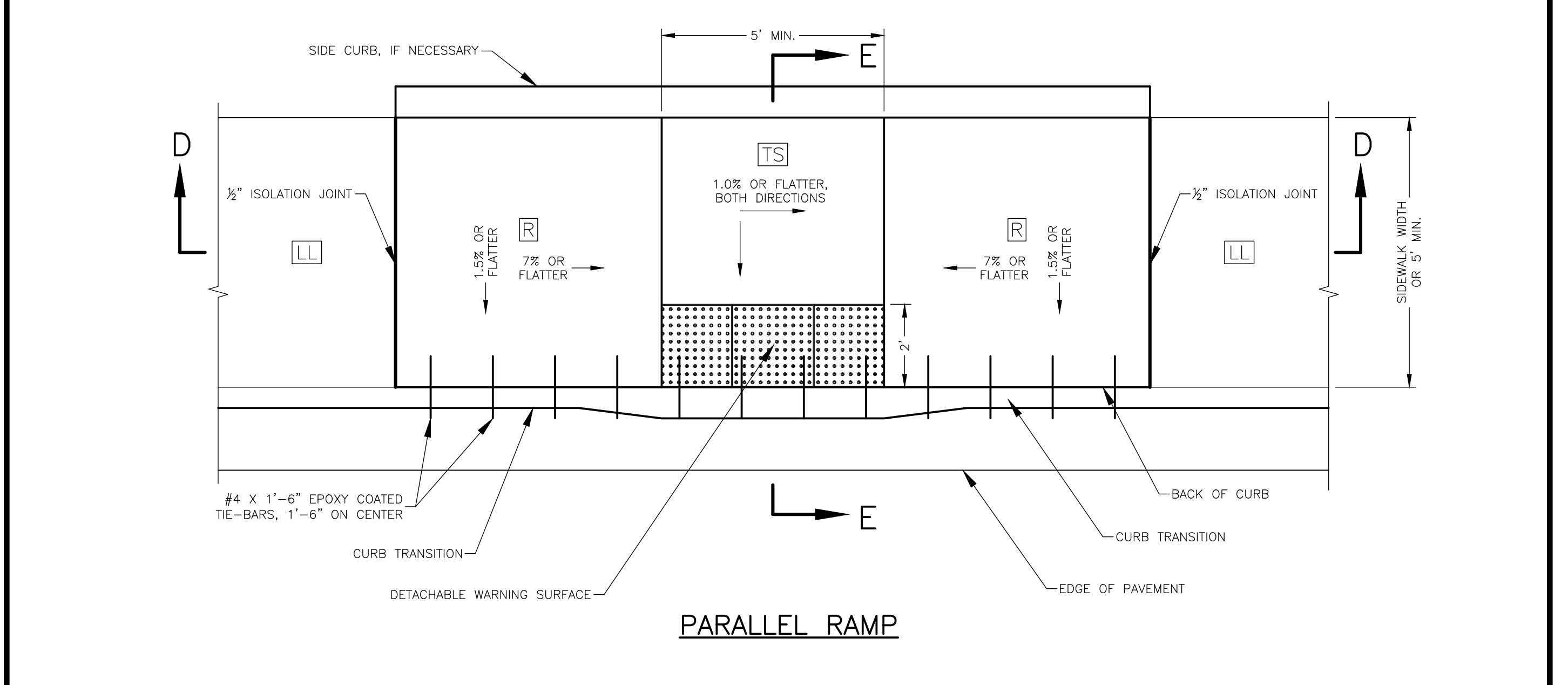

PARALLEL RAMP

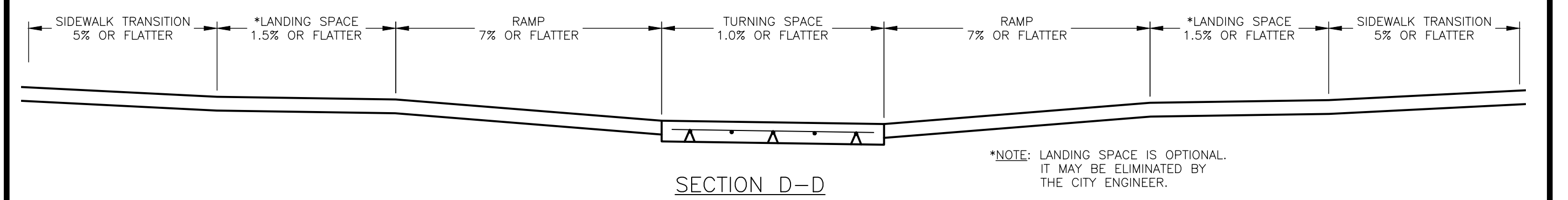

SECTION D-D

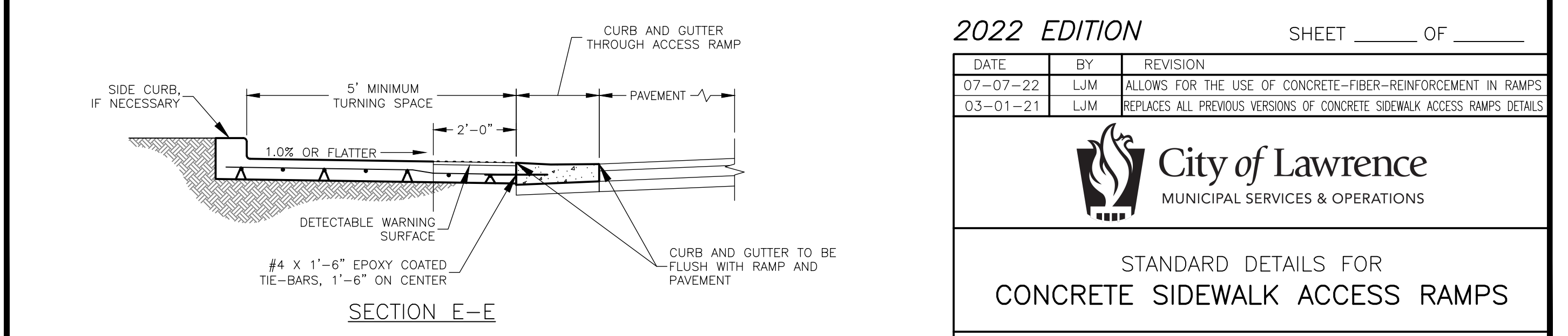

SECTION E-E

2022 EDITION SHEET ____ OF ____

DATE	BY	REVISION
07-07-22	LJM	ALLOWS FOR THE USE OF CONCRETE-FIBER-REINFORCEMENT IN RAMPS
03-01-21	LJM	REPLACES ALL PREVIOUS VERSIONS OF CONCRETE SIDEWALK ACCESS RAMPS DETAILS

City of Lawrence
MUNICIPAL SERVICES & OPERATIONS

STANDARD DETAILS FOR CONCRETE SIDEWALK ACCESS RAMPS

DAVID P. CRONIN CITY ENGINEER
CRAIG S. OWENS CITY MANAGER